

ELECTRIC PUMPS with LOCKING SOLENOID VALVE

- Locking valve provides positive load holding
- Quiet operation meets OSHA regulations (80dBA)
- Ideal for applications where a remote control is required
- 2 speed operation allows for faster cylinder advance
- Full load starting capabilities
- Internal filter keeps contamination from damaging pump
- 10 ft. hand held remote controls the solenoid valve
- Wireless hand held remote option is available
- 50 Hertz motors optional

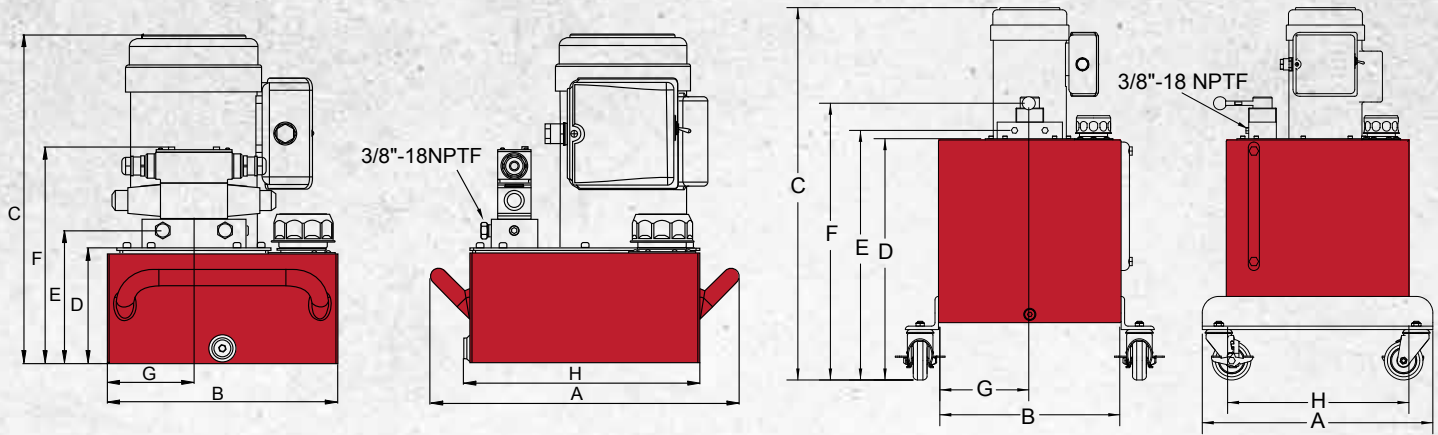

Use with Cylinder	Motor Size (hp)	Usable Oil Capacity (gal)	Model Number	Pressure Rating		Oil Output Flow Rate		Valve Type	Valve Function	Current Draw (amps)	Motor Voltage (volts)	Weight (lbs)
				1st Stage (psi)	2nd Stage (psi)	1st Stage (in ³ /min)	2nd Stage (in ³ /min)					
Single Acting	0.5	1.0	PESL0501T	350	10,000	293	18	3-Way, 3-Position	Advance/ Hold/ Return	9	115	61.5
	0.5	2.0	PESL0502T	350	10,000	293	18			9	115	65.3
	1.0	2.0	PESL1002T	700	10,000	311	37			12	115	72.6
	1.5	3.0	PESL1503T	700	10,000	476	61			17	115	90.4
	1.5	5.0	PESL1505T	700	10,000	476	61			17	115	98.0
	1.5	10.0	PESL1510T	700	10,000	476	61			17	115	118.0
	1.5	15.0	PESL1515T	700	10,000	476	61			17	115	129.0
	1.5	25.0	PESL1525T	700	10,000	592	110			17	230	150.0
	3.0	5.0	PESL3005T	700	10,000	592	110			17	230	101.0
	3.0	10.0	PESL3010T	700	10,000	592	110			17	230	125.0
	3.0	15.0	PESL3015T	700	10,000	592	110			17	230	136.0
	3.0	25.0	PESL3025T	700	10,000	592	110			17	230	157.0
Double Acting	0.5	1.0	PESML0501T	350	10,000	293	18	4-Way, 3-Position	Advance/ Hold/ Return	9	115	61.5
	0.5	2.0	PESML0502T	350	10,000	293	18			9	115	65.3
	1.0	2.0	PESML1002T	700	10,000	311	37			12	115	72.6
	1.5	3.0	PESML1503T	700	10,000	476	61			17	115	90.4
	1.5	5.0	PESML1505T	700	10,000	476	61			17	115	98.0
	1.5	10.0	PESML1510T	700	10,000	476	61			17	115	118.0
	1.5	15.0	PESML1515T	700	10,000	476	61			17	115	129.0
	1.5	25.0	PESML1525T	700	10,000	592	110			17	230	150.0
	3.0	5.0	PESML3005T	700	10,000	592	110			17	230	101.0
	3.0	10.0	PESML3010T	700	10,000	592	110			17	230	125.0
	3.0	15.0	PESML3015T	700	10,000	592	110			17	230	136.0
	3.0	25.0	PESML3025T	700	10,000	592	110			17	230	157.0



Model Number	Dimensions (in)							
	A	B	C	D	E	F	G	H
PESL0501T	12.74	10.26	19.10	4.72	5.65	11.96	8.07	12.36
PESL0502T	17.88	12.01	20.36	5.98	6.9	13.16	4.51	12.36
PESL1002T	17.88	12.01	17.88	5.98	6.90	13.16	4.51	12.36
PESL1503T	17.88	12.01	17.88	5.98	6.90	13.16	4.51	12.32
PESL1505T	16.10	12.01	17.13	5.98	6.90	13.16	4.51	12.36
PESL1510T	20.87	16.54	31.48	18.98	19.89	26.38	8.27	16.54
PESL1515T	20.87	16.54	34.63	22.13	23.04	29.53	8.27	16.54
PESL1525T	25.59	21.26	34.63	22.13	23.04	29.53	10.63	21.26
PESL3005T	16.54	12.01	26.54	12.28	13.23	15.51	4.53	12.36
PESL3010T	20.87	16.54	33.24	18.98	19.89	26.38	8.27	16.54
PESL3015T	20.87	16.54	36.39	22.13	23.04	29.53	8.27	16.54
PESL3025T	25.59	21.26	36.39	22.13	23.04	29.53	10.63	21.26
PESML0501T	12.74	10.26	19.10	4.72	5.65	11.96	8.07	12.36
PESML0502T	12.74	10.26	19.10	4.72	5.65	11.96	8.07	12.36
PESML1002T	17.88	12.01	17.88	5.98	6.90	13.16	4.51	12.36
PESML1503T	17.88	12.01	17.88	5.98	6.90	13.16	4.51	12.32
PESML1505T	16.10	12.01	17.13	5.98	6.90	13.16	4.51	12.36
PESML1510T	20.87	16.54	31.48	18.98	19.89	26.38	8.27	16.54
PESML1515T	20.87	16.54	34.63	22.13	23.04	29.53	8.27	16.54
PESML1525T	25.59	21.26	34.63	22.13	23.04	29.53	10.63	21.26
PESL3005T	16.54	12.01	26.54	12.28	13.23	15.51	4.53	12.36
PESML3010T	20.87	16.54	33.24	18.98	19.89	26.38	8.27	16.54
PESML3015T	20.87	16.54	36.39	22.13	23.04	29.53	8.27	16.54
PESML3025T	25.59	21.26	36.39	22.13	23.04	29.53	10.63	21.26